

NO	DESCRIPTION	MATERIAL	Q'TY	FINISH	REMARK
1	BODY 1	ZINE	1	NICKEL	B-BNC0184-N
2	RUBBER	SI RUBBER	1	RUBBER	RU-0010
3	WASHER 1	BRASS	1	NICKEL	W-0026-N
4	WASHER 2	BRASS	1	NICKEL	W-0027-N
5	WASHER 3	BRASS	1	NICKEL	W-0025-N
6	INSULATION	TEFLON	1	TEFLON	I-0172T
7	BODY 2	BRASS	1	NICKEL	B-TNC0085-N
8	PIN	BRASS	1	GOLD	P-TNC0222-G
9	RING	BRASS	1	NICKEL	R-0007-N

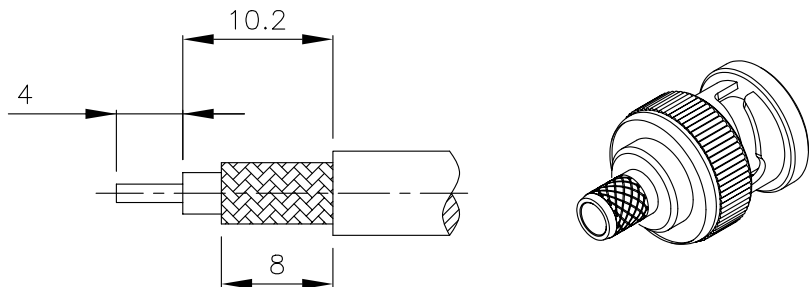

(Recommended Stripping Dimension)

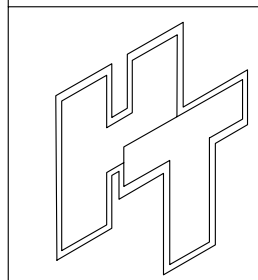
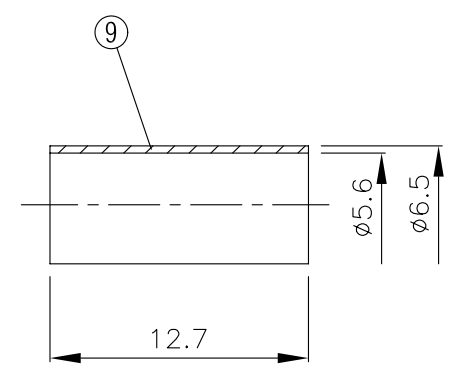
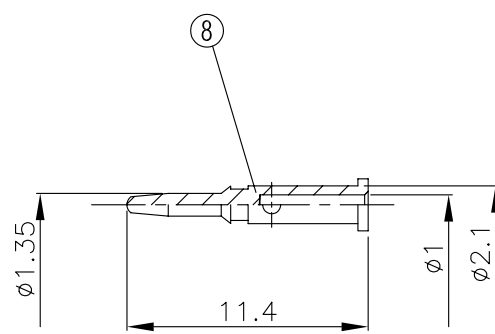
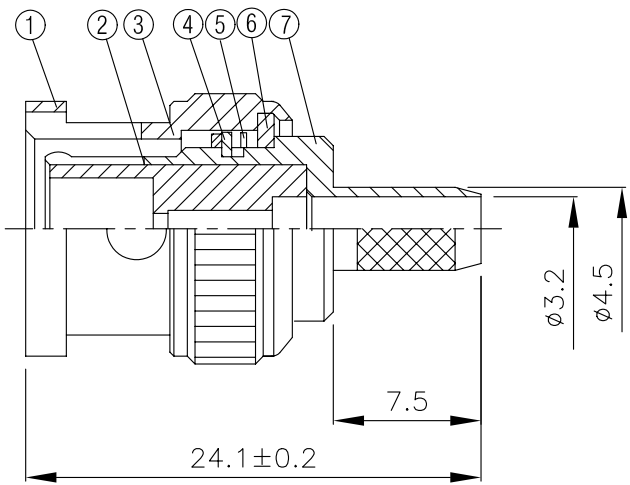

**HUS-TSAN GROUP CO., LTD.**  
P.O.BOX 40-76.TAINAN.TAIWAN,R.O.C.  
**TITLE BNC MALE CRIMP FOR RG 58U, RG141A/U**  
**PART NO. BNC-05F-TGN**  
**DRAWING NO. BNC-05F-TGN**

DRAWN	MARY	DATE	90.01.22
CHECKED	蘇姿潔	DATE	
Q.A.	馮健華	DATE	
APPROVAL	徐燦霖	DATE	
REVISION		DATE	

DIMENSIONS ARE IN MILLIMETERS			
UNLESS OTHERWISE SPECIFIED TOLERANCE			
0.5-5=±0.2	120-315=±1		
5-30=±0.4	315-1000=±1.6		
30-120±0.6	1000-2000=±2.4		
SCALE	4:1	SIZE	A

REVISION	
DESCRIPTION	ENGINEER